

The print-out is not subject to the modification service.

Intended for internal and supplier use

EN

Ident. Doc.: Druckdatum: 03.04.2023 / 13:47:55 ***** Ausdruck nicht massgetreu *****

supp No.	material no.			A	B	D	E
F	processing and surface treatment acc. to STAB-Spec.			overall length	thread length	length without	length without
	10006248 Tab. IV version 1	10006248 Tab. X version 1	10028959 Tab. I version 2			length without endfitting stud	
1	410177		410177	288	14	22	274
2	407073		407073	414	20	22	394

(c) before grinding: Hardness depth and hardness test acc. to STAB-Spec. 10258370

(d) tolerances: +0,3 after turning;
+0,3 after straightening;
+0,3 after nisliding

(e) threaded stud rough-turned dim. $\phi 8,97_{-0,06}$
thread roll tolerance 6e
thread tolerances acc. to DIN ISO 965-3

(f) rough-turned dim. thread roll tolerance 6e

(g) In the final condition, the actual profile of the thread must not exceed the maximum material limit for the tolerance zone position h at any point

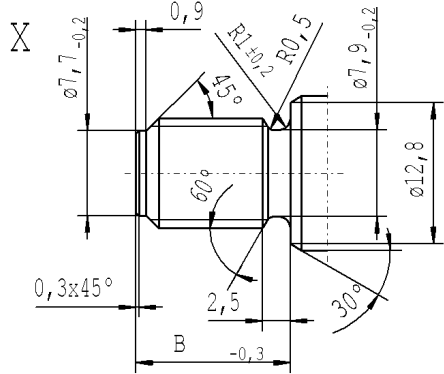

Caution!
for twin-seal dim. $D=10^{+2}$

A IAGI CQI-standards acc. to STAB-Spec. 10027692

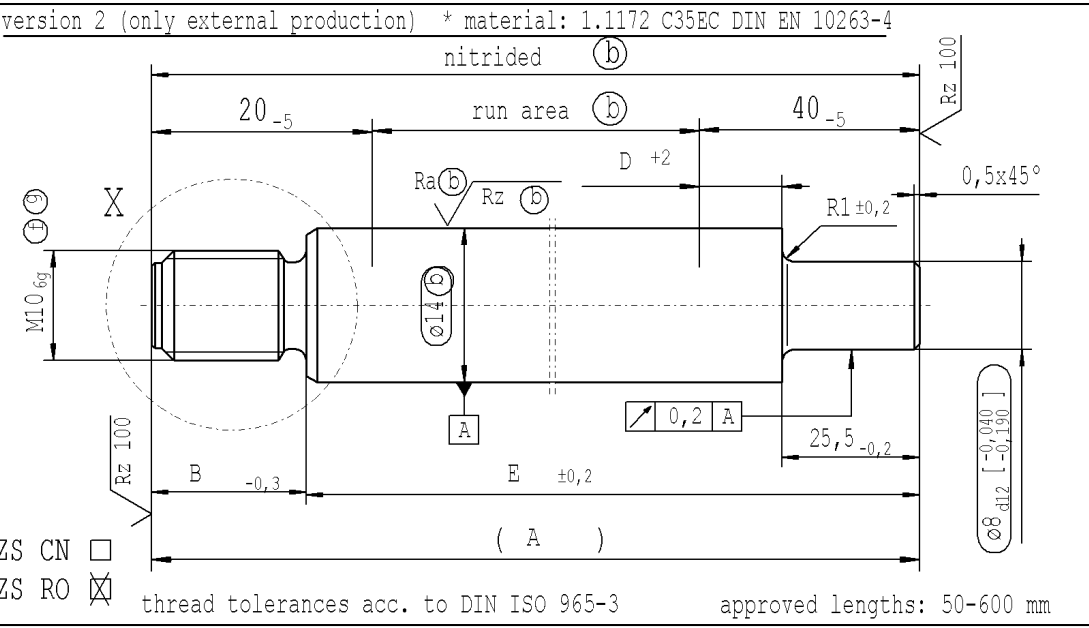
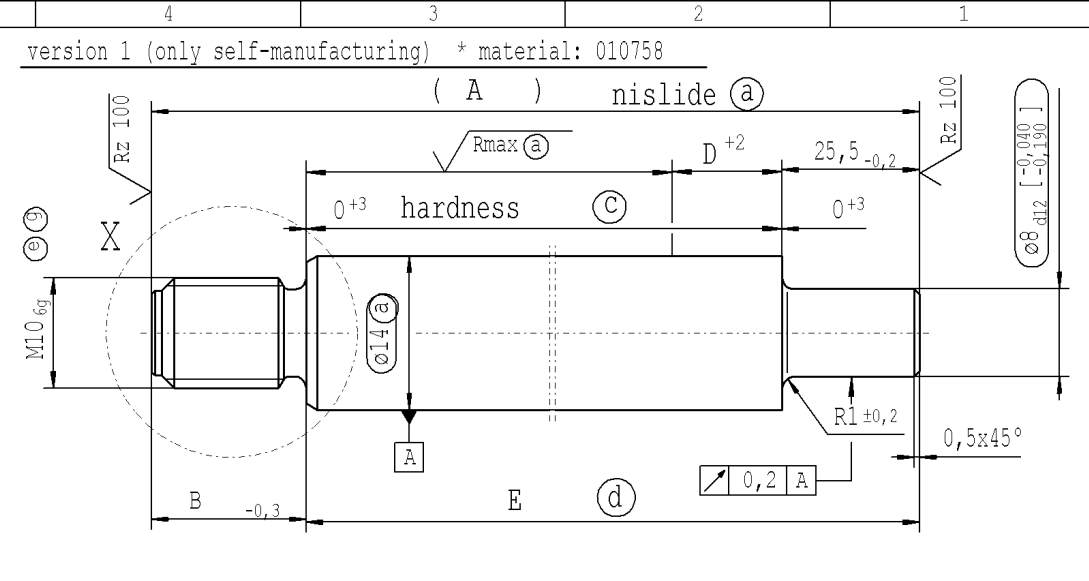

$\sqrt{Rz\ 25}$ ($\sqrt{Rz\ 100}$ $\sqrt{Rmax\ (a)}$ $Ra^{(b)}$ $Rz^{(b)}$) $\begin{matrix} +0,2 \\ \swarrow \\ \downarrow \\ \searrow \\ \downarrow \\ \swarrow \\ \downarrow \\ \searrow \\ \downarrow \\ \swarrow \\ \downarrow \\ \searrow \\ \downarrow \end{matrix}$ $\begin{matrix} +0,1 \\ \swarrow \\ \downarrow \\ \searrow \end{matrix}$ $\begin{matrix} -0,2 \\ \swarrow \\ \downarrow \\ \searrow \end{matrix}$

sheet 1
of 1

DE: X	EN: X	ES:	IT:	PR:	FR:	RO: X	CAD created document; handwritten changes not permitted
new	INITIAL RELEASE						
old	-						
Field	-						
Date/Name	23.05.2022 Hein						
Chg. No.	-						
Rev.	0						

Material: *

All dimensions are in mm

Scale: (Original DIN A3) 2:1

Surface finish DIN EN ISO 1302

Replaces:

Environmental protection acc. to STAB-Spec. 10005649

Marking of special characteristics according to STAB-Spec. 10270932

Dimensions without tolerances DIN ISO 2768 mK

We reserve all rights to this document, to any patents or patent registrations related hereto, and to the duplication, retransmission by third parties and misc. use. Any use of this document is not permitted without the written consent of STABILUS.

Document No.: 10307672

Material No.:

STABILUS PISTON ROD

Drawn by: 23.05.2022 Hein
Checked: 23.05.2022 Klinkner

***** Druckdatum: 03.04.2023 / 13:47:55 ***** Ausdruck nicht massgetreu *****