

Ident. Doc.: SN 53.11-006/097mm. 16/02/2023 - 8:27

| F | supp. No. | material no. | | | | A | B | C | D |
|---|-----------|---|------------------------|---|-------------------------------|-------|----|------|---|
| | | table IV Nislide black for STUS / STMX table IV acc. STAB-Spec. 10210309 | table X Nislide "G" | table VIII Nislide black polished | table XVI Nislide black | | | | |
| | 87 | 669461 | 669461 | | | 277.0 | 10 | 22.5 | 2 |
| | 88 | 713198 | 713198 | | | 342.0 | 9 | 22.5 | 2 |
| E | 89 | 890538 | | 890538 | | 318.0 | 10 | 22.5 | 2 |
| | 90 | 139362 | 139362 | | | 366.0 | 9 | 10.5 | 1 |
| | 91 | 142947 | 142947 | | | 285.0 | 9 | 10.5 | 1 |
| | 92 | 862573 | 862573 | | | 277.0 | 9 | 22.5 | 2 |
| | 93 | 288259 | 288259 | | | 342.0 | 10 | 10.5 | 1 |
| | 94 | 919933 | | | | 297.0 | 9 | 22.5 | 2 |
| | 95 | | | | 966777 | 297.0 | 9 | 22.5 | 2 |
| D | 96 | 347054 | | | | 291.0 | 9 | 10.5 | 1 |
| | 97 | 655124 | 655124 | | | 246.0 | 9 | 22.5 | 2 |
| | 98 | 456277 | 456277 | | | 276.0 | 9 | 10.5 | 1 |
| | 99 | 286110 | 286110 | | | 300.0 | 9 | 22.5 | 2 |
| | 100 | | | 304991 | | 276.0 | 9 | 10.5 | 1 |
| | 101 | 455322 | 455322 | | | 327.0 | 10 | 22.5 | 2 |
| C | 102 | 052128 | 052128 | | | 273.0 | 9 | 22.5 | 2 |
| | 103 | 827445 | 827445 | | | 210.0 | 9 | 10.5 | 1 |
| | 104 | 321722 | 321722 | | | 387.0 | 9 | 22.5 | 2 |
| | 105 | 693606 | 693606 | | | 252.0 | 10 | 10.5 | 1 |
| | 106 | 807848 | 807848 | | | 381.0 | 9 | 22.5 | 2 |
| | 107 | 987337 | 987337 | | | 267.0 | 9 | 10.5 | 1 |
| | 108 | 122158 | 122158 | | | 243.0 | 9 | 10.5 | 1 |
| B | 109 | 245245 | 245245 | | | 264.0 | 10 | 10.5 | 1 |
| | 110 | 848242 | 848242 | | | 279.0 | 9 | 10.5 | 1 |
| | 111 | 284681 | | 284681 | | 324.0 | 10 | 22.5 | 2 |
| | 112 | 481617 | 481617 | | | 255.0 | 10 | 10.5 | 1 |

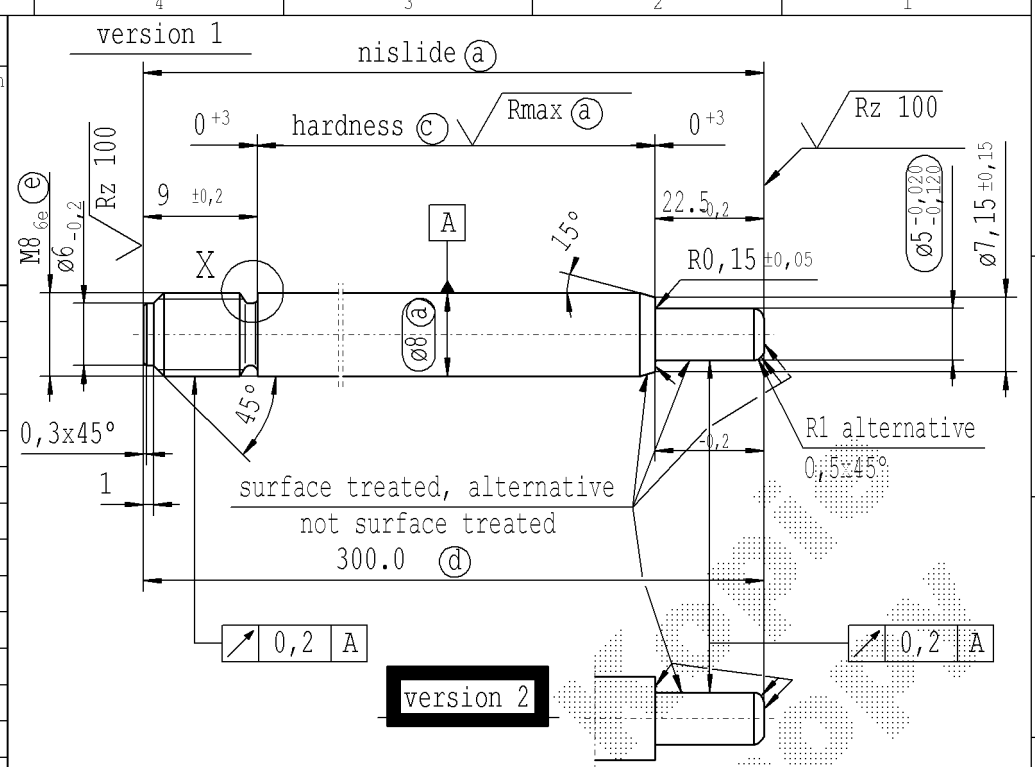

- (a) piston rod processing per STAB-Spec. 10006248
- (c) before grinding:
Hardness depth and hardness test acc. to STAB-Spec. 10258370
- (d) tolerance +0,2 after turning
+0,3 after straightening
+0,3 after nisliding
- (e) threaded stud pre-turned dim. $\phi 7,14$
thread roll tolerance 6e
thread tolerance per DIN ISO 965-3

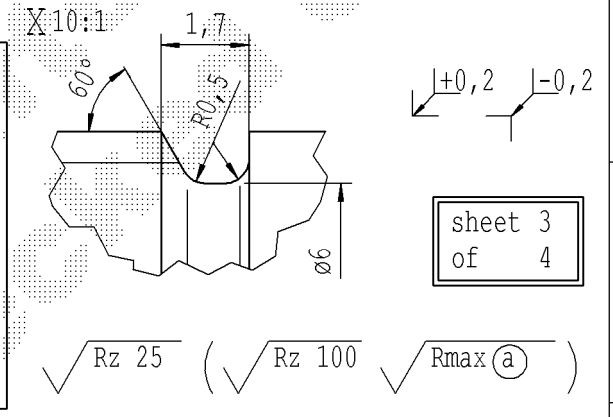

| | | | | | | | | | | | | | | | | | | | | | | | | | | | | | |
|-----------|------------------|------------------------------|-----|-----|-----|------------------|--|--|--|--|--|--|--|--|--|---|--|--|----------------------------|--|--|------|--|--|--|--|--|--|--|
| A | | | | | | | | | | AIAG CQI-standards acc. to STAB-Spec. 10027692 | | | | | | | | | | Environmental protection acc. to STAB-Spec. 10005649 | | | | | | | | | |
| DE: X | EN: X | ES: | IT: | PR: | FR: | RO: X | CAD created document handwritten changes not permitted | | | Material: mat. no.: 010731 | | | All dimensions are in mm | | | Identification of important characteristics | | | Date | | | Name | | | | | | | |
| new | Tab.XVI | Creation of romanian drawing | | | | 9 | © = acc. STAB-Spec. 10258370 | | | Edge tolerances acc. to DIN ISO 13715 | | | Scale: (Original DIN A3) 2:1 | | | Dimensions without tolerances DIN ISO 2768-mK | | | Drawn by 04.09.1992 Kirsch | | | | | | | | | | |
| old | - | - | | | | 10 | © = RHT 0,4 0,7 mm | | | Surface finish: DIN EN ISO 1302 | | | We reserve all rights to this document, to any patents or patent registrations related hereto, and to the duplication, retransmission by third parties and misc. use. Any use of this document is not permitted without the written consent of STABILUS. | | | Checked 07.05.2019 Milles | | | Document No.: 10003803 | | | | | | | | | | |
| Field | - | - | | | | Pos.66 B | B 4 | | | Regulices: SN 53.11-08/97 | | | STABILUS | | | PISTON ROD | | | Material No.: | | | | | | | | | | |
| Date/Name | 16.11.2015 Höfer | 17.03.2016 YaMueller | | | | 29.04.2016 Höfer | 07.05.2019 Jablonski | | | | | | | | | | | | | | | | | | | | | | |
| Chg. No. | 630705 | 635493 | | | | 637297 | 678352 | | | | | | | | | | | | | | | | | | | | | | |
| Rev. | 24 | 25 | | | | 26 | 27 | | | | | | | | | | | | | | | | | | | | | | |