

supp No.	material no.	A	B	E	F
	surface treatment processing acc. to STAB-Spec. 10005649 table XVI optimized Mslide black	overall length	stud length piston side	length without endfitting stud	version
1	630047	207.0	10.5	197.5	1
2	639846	133.0	10.5	123.5	1
3	652035	375.0	10.5	365.5	1
4	660639	117.0	10.5	107.5	1
5	662312	291.0	10.5	281.5	1
6	666614	267.0	10.5	257.5	1
7	677847	99.0	10.5	89.5	1
8	679042	126.5	10.5	117.0	1
9	679759	306.0	10.5	296.5	1
10	696011	208.0	10.5	198.5	1
11	696489	217.5	10.5	208.0	1
12	698640	201.0	11	191.5	1
13	711307	168.0	10.5	158.5	1
14	714892	114.0	10.5	104.5	1
15	715609	210.0	10.5	200.5	1
16	724930	244.0	10.5	234.5	1

Ⓐ piston rod processing per STAB-Spec. 10005649

Ⓑ before grinding:
Hardness depth and hardness test acc. to STAB-Spec. 10258370

Ⓒ tolerance ± 0.2 after turning
 ± 0.3 after straightening
 ± 0.3 after nisliding

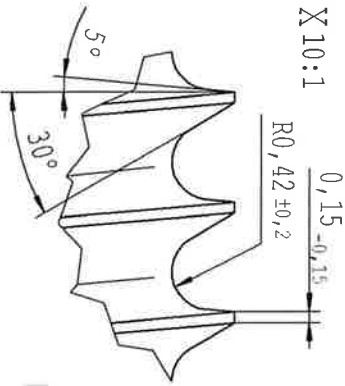

X10:1

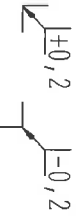

Rz 25

Rz 100

Rmax Ⓐ

Environmental protection acc. to STAB-Spec. 10005649

Material: Mat. No. 010731

Ridge tolerance acc. to DIN ISO 13075

Surface finish DIN EN ISO 1302

Replaces:

All dimensions are in mm

Scale: 2:1 (original DIM A3)

We reserve all rights to this document, to any patents or patent registrations related hereto, and to the duplication, reproduction or distribution of this document without the written consent of STABILUS.

Marking of special characteristics according to STAB-Spec. 10270932

Dimensions without tolerances DIN ISO 2768-mK

Drawn by: 02.03.2020 JaldonSKI

Checked: 02.01.2020 Killes

Date: 02.01.2020

Name: JaldonSKI

Document No.: 10275482

Material No.:

version 1

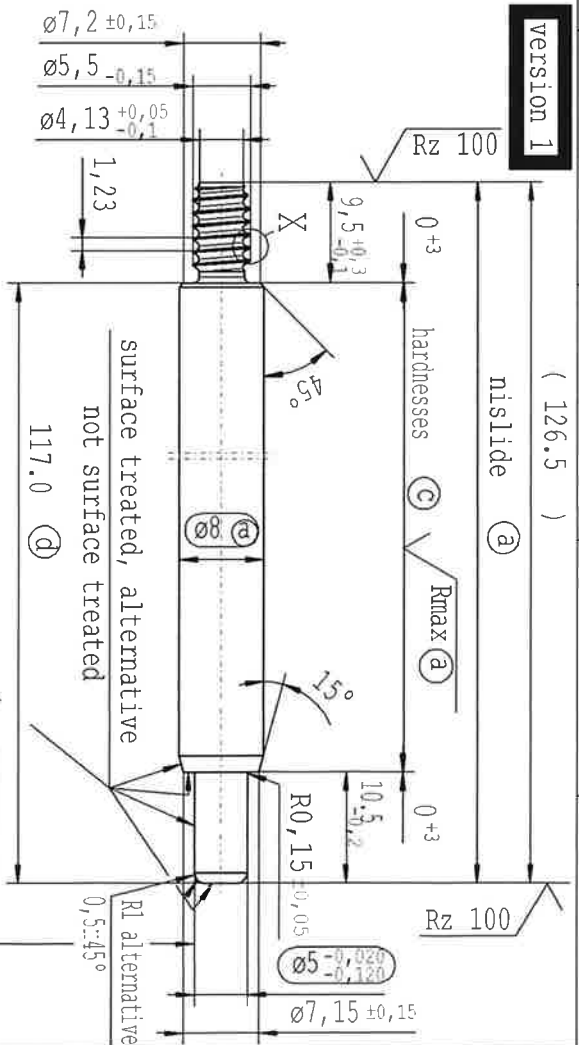

pre-worked:

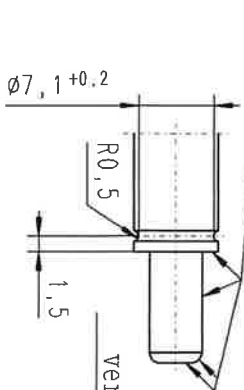
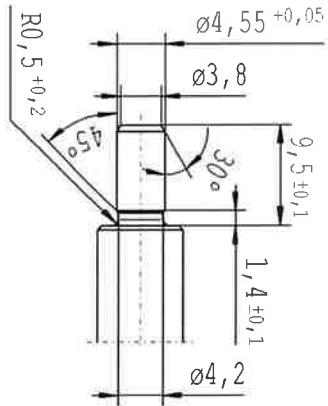

version 2

version 3

Sheet 1 of 9

STABILUS

PISTON ROD