

The print-out is not subject to the modification service.

CONFIDENTIAL! Intended for internal and supplier use

EN

Ident. Doc.:

Date: 29/11/2023 - 11:59

supp No.	material no.			A	E
	processing and surface treatment acc. to STAB-Spec.			overall length	length without endfitting stud
	10006248 Tab. XVI optimized	10006248 Tab. X	10028959 Tab. I		
	(a) version 1	(a) version 1	(b) version 2		
21	539717	539717	539717	70.0	62.0
22	540912	540912	540912	144.0	136.0
23	542107	542107	542107	255.0	247.0
24	543063	543063	543063	140.0	132.0
25	543780	543780	543780	149.5	141.5
26	544258	544258	544258	194.0	186.0
27	545214	545214	545214	219.0	211.0
28	545692	545692	545692	201.0	193.0
29	546170	546170	546170	141.0	133.0
30	547126	547126	547126	297.0	289.0
31	550472	550472	550472	176.0	168.0
32	551667	551667	551667	62.5	54.5
33	553340	553340	553340	195.0	187.0
34	555491	555491	555491	117.0	109.0
35	557164	557164	557164	242.0	234.0
36	557642	557642	557642	91.0	83.0
37	558120	558120	558120	125.0	117.0
38	558598	558598	558598	105.0	97.0
39	559076	559076	559076	82.0	74.0

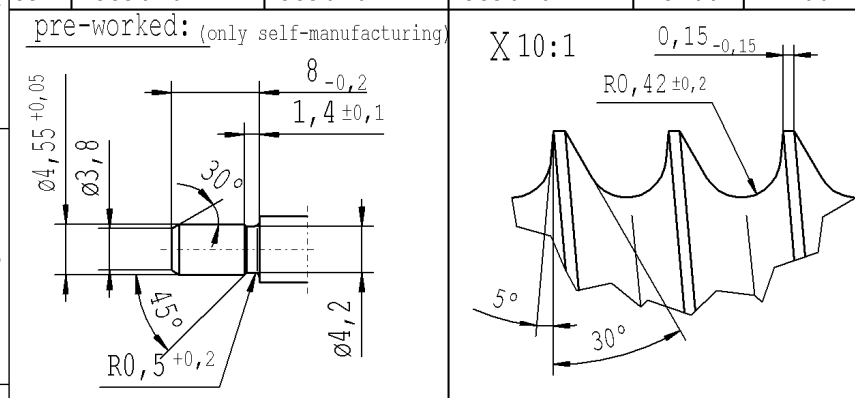
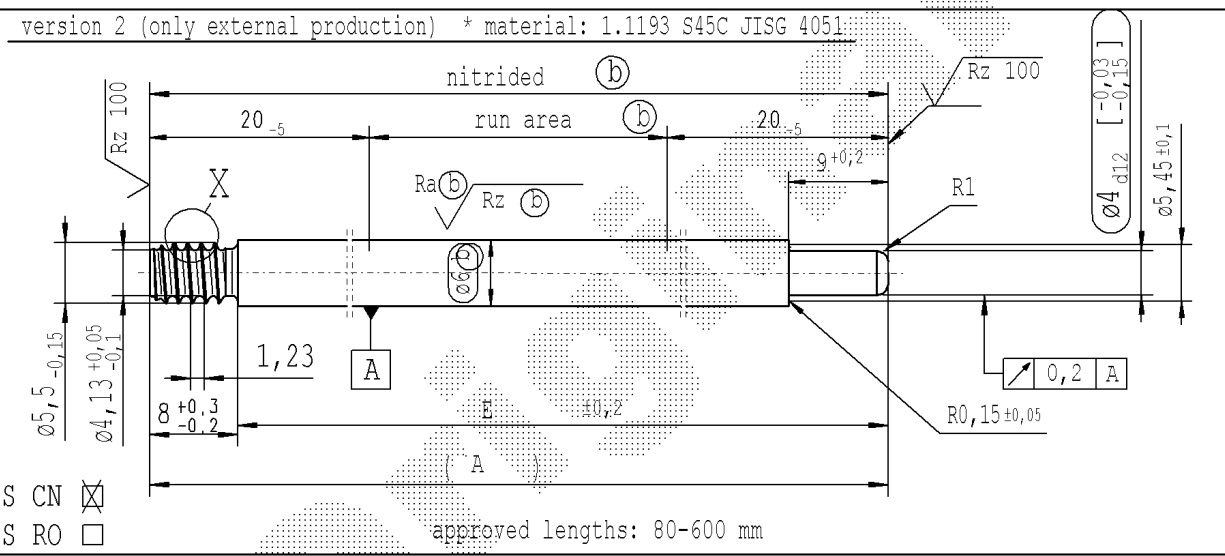
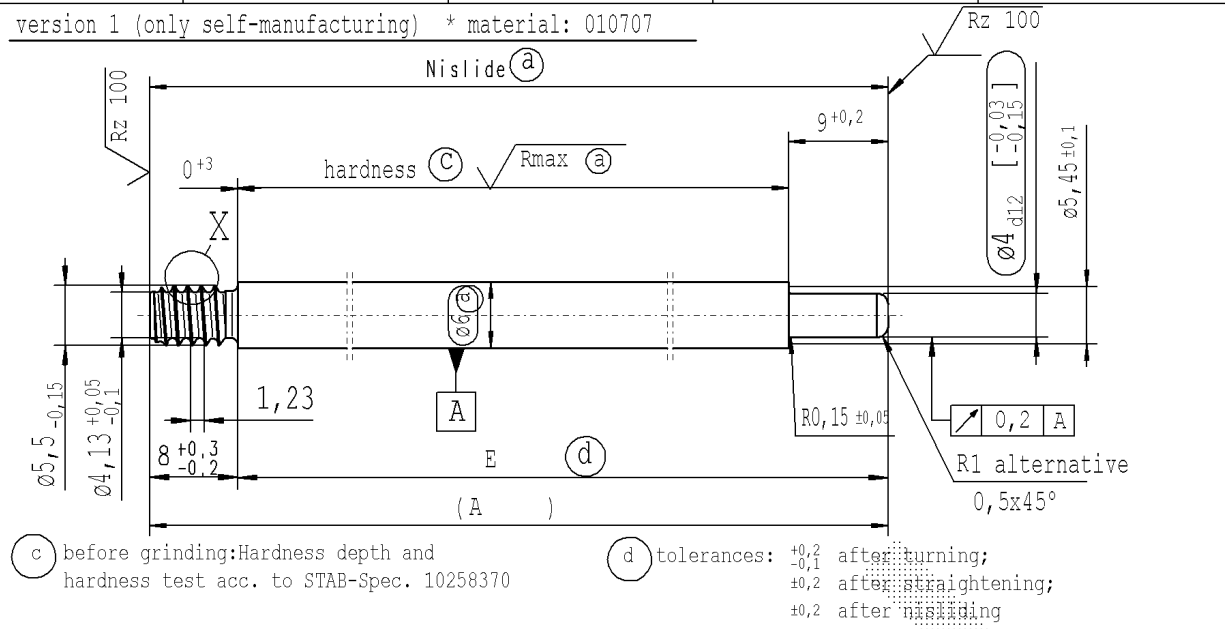

AIAG CQI-standards acc. to STAB-Spec. 10027692 Environmental protection acc. to STAB-Spec. 10005649

DE: X	EN: X	ES:	IT:	PR:	FR:	RO: X	CAD created document; handwritten changes not permitted	Material: *	All dimensions are in mm	Marking of special characteristics according to STAB-Spec. 10270932	Date: 29.11.2010	Name: Höfer
new	Tab.XVI; Tab. X; no technical change, no new first sample required						Vers.2: 9 <sup>+0,2</sup>	Edge tolerances acc. to DIN ISO 13715	Scale: (Original DIN A3) 2:1	Dimensions without tolerances DIN ISO 2768-mK	Checked: 15.09.2023	Klinkner
old	Tab.IV						Vers.2: 9 <sup>-0,2</sup>	Surface finish: DIN EN ISO 1302	We reserve all rights to this document, to any patents or patent registrations related hereto, and to the duplication, retransmission by third parties and misc. use. Any use of this document is not permitted without the written consent of STABILUS.			
Field	-						C2	Replaces:	Document No.: 10177465			
Date/Name	10.10.2022 Jablonski						15.09.2023 Jablonski		Material No.:			
Chg. No.	715932						725945					
Rev.	6						7					

**STABILUS**

PISTON ROD

sheet 2 of 3