

The print-out is not subject to the modification service.

Intended for internal and supplier use

Ident. Doc.: SN 53.11.160840 datum: 28/11/2022 - 16:37

| supp No. | material no. | | | | KOST without surface treatment only for STUS / STMX | A | B | C | E | F |
|------------|---|--------------------------|---|------------------------|--|----------------|---------------------------------|----------------------------|------------------------------------|---------|
| | table IV Nislide black for STUS / STMX table IV acc. STAB-Spec. 10210309 | table V Nislide light | table VIII Nislide black polished | table X Nislide "G" | | overall length | stud length end-fitting side | stud length piston side | length without end-fitting stud | version |
| 279 | 7242ZM | | | 7242ZM | 258.0 | 7 | 10.5 | 251.0 | 1 | |
| 281 | 002117 | | | 002117 | 157.0 | 7 | 10.5 | 150.0 | 1 | |
| 282 | 003464 | | | 003464 | 204.0 | 10 | 10.5 | 194.0 | 1 | |
| 283 | 003598 | | | 003598 | 238.5 | 7 | 10.5 | 231.5 | 1 | |
| 289 | 007836 | | | 007836 | 198.0 | 10 | 10.5 | 188.0 | 1 | |
| 290 | 009012 | | | 009012 | 216.0 | 7 | 10.5 | 209.0 | 1 | |
| 292 | 009099 | | | 009099 | 172.5 | 7 | 10.5 | 165.5 | 1 | |
| 295 | 008539 | | | 008539 | 235.5 | 10 | 10.5 | 225.5 | 1 | |
| 298 | 013521 | | | 013521 | 240.0 | 10 | 10.5 | 230.0 | 1 | |
| 303 | 010985 | | | 010985 | 213.0 | 7 | 10.5 | 206.0 | 1 | |
| 304 | 011039 | | | 011039 | 228.0 | 7 | 10.5 | 221.0 | 1 | |
| 305 | 011043 | | | 011043 | 174.0 | 7 | 10.5 | 167.0 | 1 | |
| 310 | 027832 | | | 027832 | 301.0 | 10 | 10.5 | 291.0 | 1 | |
| 313 | | | | 031261 | 298.0 | 10 | 10.5 | 288.0 | 1 | |
| 316 | 504324 | | | 504324 | 163.0 | 7 | 10.5 | 156.0 | 1 | |
| 317 | 524161 | | | 524161 | 165.0 | 7 | 22.5 | 158.0 | 2 | |
| 318 | 530614 | | | 530614 | 174.0 | 7 | 22.5 | 167.0 | 2 | |
| 321 | 303233 | | | 303233 | 153.0 | 10 | 10.5 | 143.0 | 1 | |
| 322 | 960097 | | | 960097 | 142.0 | 7 | 10.5 | 135.0 | 1 | |
| 324 | 554959 | | | 554959 | 210.0 | 10 | 10.5 | 200.0 | 1 | |
| 325 | | 381924 | | | 150.0 | 7 | 10.5 | 143.0 | 1 | |
| 326 | 687126 | | | 687126 | 177.0 | 7 | 10.5 | 170.0 | 1 | |
| 327 | | | | 325044 | 294.0 | 10 | 10.5 | 284.0 | 1 | |
| 328 | 163720 | | | 163720 | 127.0 | 7 | 22.5 | 120.0 | 2 | |
| 329 | | | | 512900 | 84.0 | 7 | 10.5 | 77.0 | 1 | |
| 330 | 851324 | | | 851324 | 249.0 | 10 | 10.5 | 239.0 | 1 | |

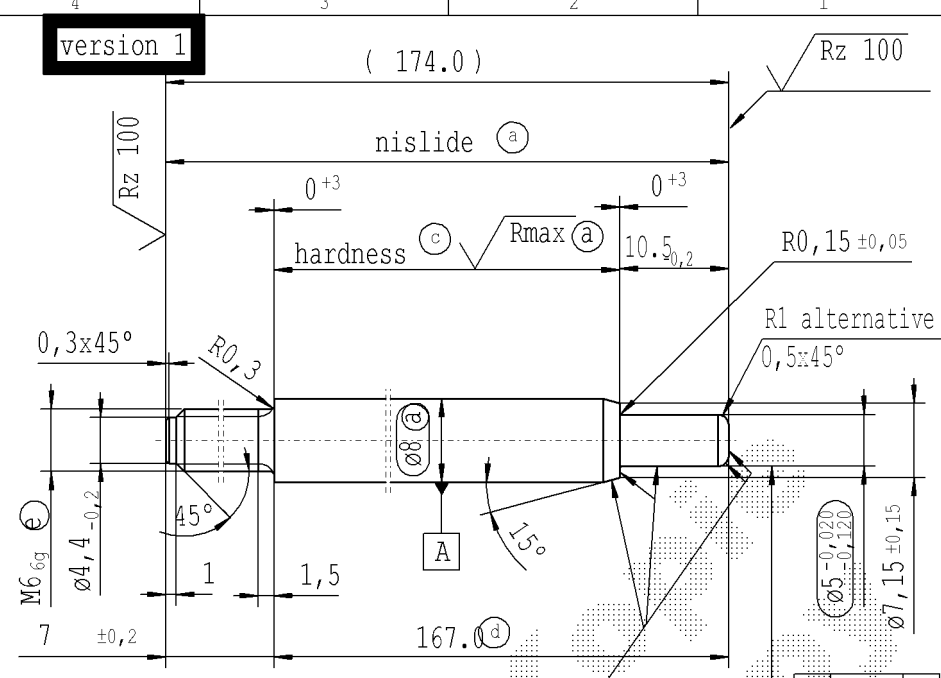

surface treated, alternative not surface treated

version 2

sheet 6 of 11

- (a) piston rod processing per STAB-Spec. 10006248
- (c) before grinding: Hardness depth and hardness test acc. to STAB-Spec. 10238370
- (d) tolerance $\pm 0,2$ after turning $\pm 0,3$ before straightening $\pm 0,3$ before nisliding
- (e) threaded stud rough-turned dimension $\pm 0,20$ thread roll tolerance $\pm 0,06$ thread tolerances per DIN ISO 965-3

| | | | | | | | | | | | | | | | | | | | | | | | | | | | | | | | | | | | | | | | |
|-----------|------------------------|----------|-----------------------------|-------|------------------|-------|--|--|----------------------|--|------------------------------|----------------|---------------------------------------|--|--|--|-----------|--------------------------|--|--|--|--|--|--|--|--|--|---|---------------|--|---------------|--|----------|------------|--------|--|--|------|------|
| A | | | | | | | | | | AIAG CQI-standards acc. to STAB-Spec. 10027692 | | | | | | | | | | Environmental protection acc. to STAB-Spec. 10005649 | | | | | | | | | | | | | | | | | | | |
| DE: X | EN: X | ES: X | IT: X | PR: X | FR: | RO: X | CRD created document handwritten changes not permitted | | | | | | | | | | Material: | All dimensions are in mm | | | | | | | | | | Identification of important characteristics | | | | | | | | | | Date | Name |
| new | R1 alternative 0,5x45° | Tab.IV | Supplier / KOST w/o surface | | | | Creation of romanian drawing | | | | ⊙ = acc. STAB-Spec. 10238370 | mat.no: 010731 | Scale: (Original DIN A3) 2:1 | | | | | | | | | | Dimensions without tolerances DIN ISO 2768-mK | | | | | | | | | | Drawn by | 29.04.1992 | Kirsch | | | | |
| old | 0,5x45° alternative R1 | TAB.IX+X | internal / - | | | | - | | | | ⊙ = RHT 0,4 ... 0,27 mm | | Edge tolerances acc. to DIN ISO 13715 | | | | | | | | | | We reserve all rights to this document, to any patents or patent registrations related hereto, and to the duplication, retransmission by third parties and misc. use. Any use of this document is not permitted without the written consent of STABILUS. | | | | | | | | | | Checked | 08.05.2019 | Miles | | | | |
| Field | E/1 | | 205893 | | - | | C 3-4 | | | | | | | | | | | | | | | | | | | | | | Document No.: | | 10003766 | | | | | | | | |
| Date/Name | 19.03.2009 Hein | | 17.02.2012 H6 | | 19.05.2014 Donat | | 07.04.2016 YaMueller | | 08.05.2019 Jablonski | | | | | | | | | | | | | | | | | | | | | | Material No.: | | | | | | | | |
| Chg. No. | 571413 | | 595288 | | 613650 | | 635494 | | 678350 | | | | | | | | | | | | | | | | | | | | | | | | | | | | | | |
| Rev. | 41 | | 42 | | 43 | | 44 | | 45 | | | | | | | | | | | | | | | | | | | | | | | | | | | | | | |

STABILUS

PISTON ROD