

CONFIDENTIAL!  
Intended for internal use only

supp. No.	material no.			A	B
	surface treatment processing acc. to STAB-Spec. 10006248				
	table IV Nislid black	table VIII Nislid black	table X Nislid "G"	overall length	stud length end fitting side
29	248085			111.5	16
30	941903			146.5	16
31	061428			122.5	16
32			380254	132.5	16
33			261474	224.5	16
35			512188	302.5	16
36			440489	161.5	20
37			505497	158.5	16
38	653200			299.5	16
40			275105	164.5	16
43			189307	308.5	16
45			737096	233.5	16
46	587720			191.5	16
47		089646		128.5	16
48			935706	200.5	20
49			709610	180.0	16
50			746898	104.5	16

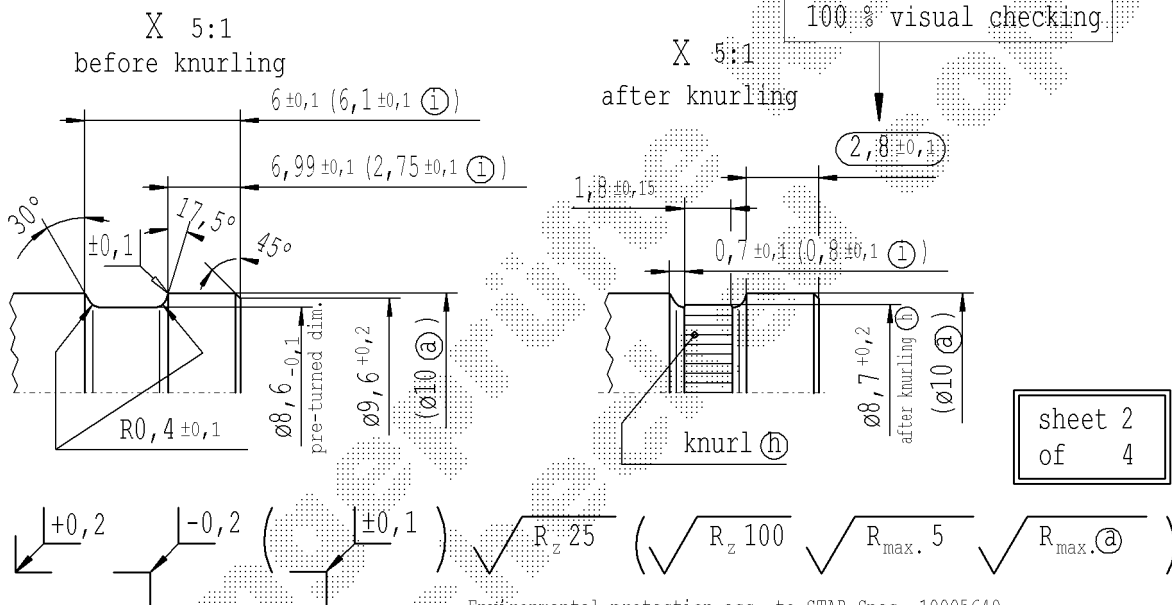
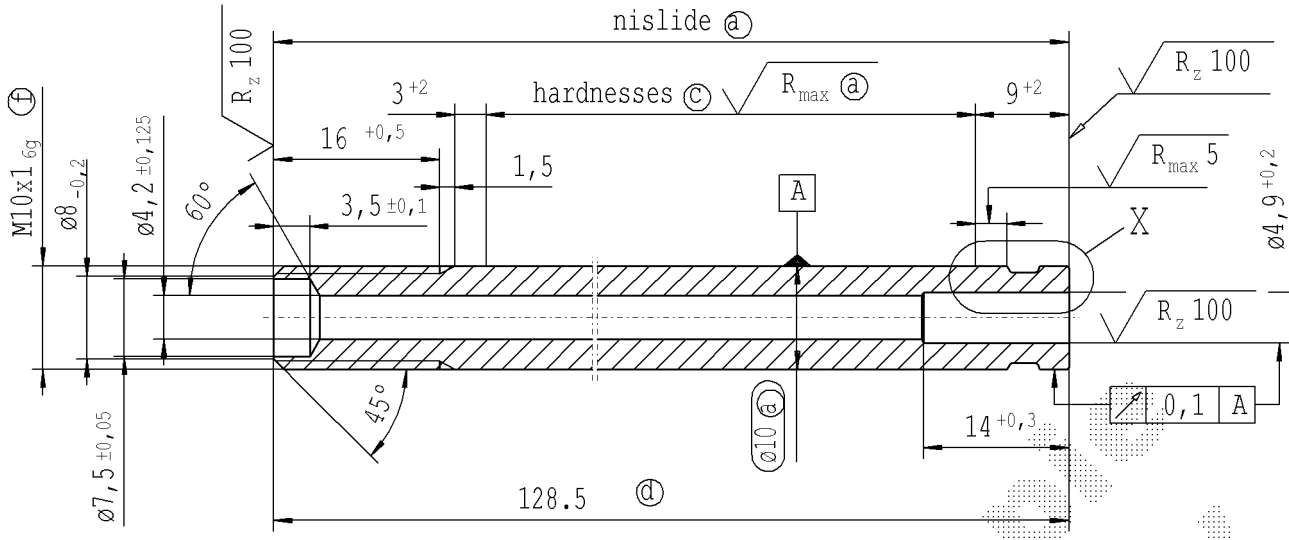

Control dimension!  
100% visual checking.

sheet 2  
of 4

- Ⓐ piston rod processing acc. to STAB-Spec. 10006248
- Ⓑ before grinding:  
Hardness depth and hardness test acc. to STAB-Spec. 10258370
- Ⓒ tolerance  $\pm 0.1$  after turning  
 $\pm 0.3$  after straightening  
 $\pm 0.3$  after nisliding
- Ⓓ threaded stud pre-turned dimension  $\varnothing 9,29^{+0,05}$   
thread roll tolerance 6g  
thread tolerances acc. to DIN ISO 965-3
- Ⓔ knurl-profile manufactured with knurl roll DIN 82 - RAA 0,5
- Ⓕ dim. before grinding at piston rod dia.  $10,45_{-0,11}$

100% cleanliness of through hole

Environmental protection acc. to STAB-Spec. 10005649

DE: X	EN: X	ES:	IT:	PR:	FR:	RO: X	CAD created document handwritten changes not permitted		Material:	All dimensions are in mm	Marking of special characteristics according to STAB-Spec. 10270932	Date	Name
new	table X	Rumanian Version	Permanent add. inspection 014/01	Ⓒ = acc. STAB-Spec. 10258370	100% cleanliness of through hole	material no.: 010154	Scale: (Original DIN A3) 2:1	Dimensions without tolerances DIN ISO 2768 mK	Drawn by	30.01.2001	Kesselhei		
old	table IV	-	Temporary add. inspection 014/01	Ⓒ = RHT 0,4 ... 0,7 mm	Temporary add. inspection 014/01	Edge tolerances acc. to DIN ISO 13715	We reserve all rights to this document, to any patents or patent registrations related hereto, and to the duplication, retransmission by third parties and misc. use. Any use of this document is not permitted without the written consent of STABILUS.		Checked	08.06.2021	Klinkner		
Field	all Mat.Nr.	-	B-C 6	C 7-8	B/5-6	Surface finish acc. to DIN EN ISO 1302	Document No.:		10015662				
Date/Name	04.06.07 Hö	11.02.2009 Geisbüsch	25.03.2019 Höfer	14.05.2019 Jablonski	08.06.2021 Hein	Reguläres:	Material No.:		10015662				
Chg. No.	556857	571242	671363	678671	677895	<b>STABILUS</b>	PISTON ROD						
Rev.	6	7	8	9	10								