

CONFIDENTIAL!  
Intended for internal use only

supp. No.	material no.				A	B
	table IV Nislide black	table VIII Nislide black	table V Nislide light	table X Nislide "G"	overall length	stud length end-fitting side
1				0907CC	59.5	16
4				2541CU	71.5	16
5				2744CS	56.5	22
7	2616CG				454.5	16
8				4243CP	68.5	16
9				4277CF	188.5	16
10	570244			4284CN	74.5	16
11				4288CU	83.5	16
12				4291CW	143.5	16
13				4301CP	98.5	16
14				4303CF	122.5	16
15		4055NX		4306CR	311.5	16
16				4308CH	131.5	16
17				4311CJ	293.5	16
18	004306			4312CE	203.5	16
19				4319CX	161.5	16
20				4321CD	119.5	16
21				4323CU	260.5	16
22				4325CK	242.5	16
23				4349CF	278.5	16
24				4367CD*	89.5	16
25				4369CU	62.5	16
26				4378CT	200.5	16
27				4215CX	56.5	16
28				4221CK	104.5	16
29				4237CB	65.5	16
30				4414CO	179.5	16
31				4438CJ	80.5	16
32				4441CL	221.5	16
33	390479			4443CB	140.5	16

100% cleanliness of through hole

① piston rod processing per STAB-Spec. 10006248

② before grinding:  
Hardness depth and hardness test acc. to STAB-Spec. 10258370

③ tolerance  $\pm 0,1$  after turning  
 $\pm 0,3$  after straightening  
 $\pm 0,3$  after nisliding

④ threaded stud pre-turned dimension  $\varnothing 9,29^{+0,05}$   
thread roll tolerance 6e  
thread tolerances acc. to DIN ISO 965-3

⑤ knurl-profile manufactured with knurl roll DIN 82 - RAA 0,5  
dim. before grinding at piston rod dia.  $10,45_{-0,11}$

DE: X	EN: X	ES: X	IT:	PR:	FR:	RO: X	CRD created document handwritten changes not permitted
new	thread roll tolerance 6e	Permanent add. inspection 014/01	③ = acc. STAB-Spec. 10258370	100% cleanliness of through hole			
old	thread roll tolerance 6g	Temporary add. inspection 014/01	③ = RHT 0,4 ... 0,7 mm	Permanent additional inspection 014/01			
Field	B5	B7-8	C 4-6	D/5			
Date/Name	16.06.2015 Donat	25.03.2019 Höfer	10.05.2019 Jablonski	08.06.2021 Hein			
Chg. No.	639400	671363	678485	677895			
Rev.	24	25	26	27			

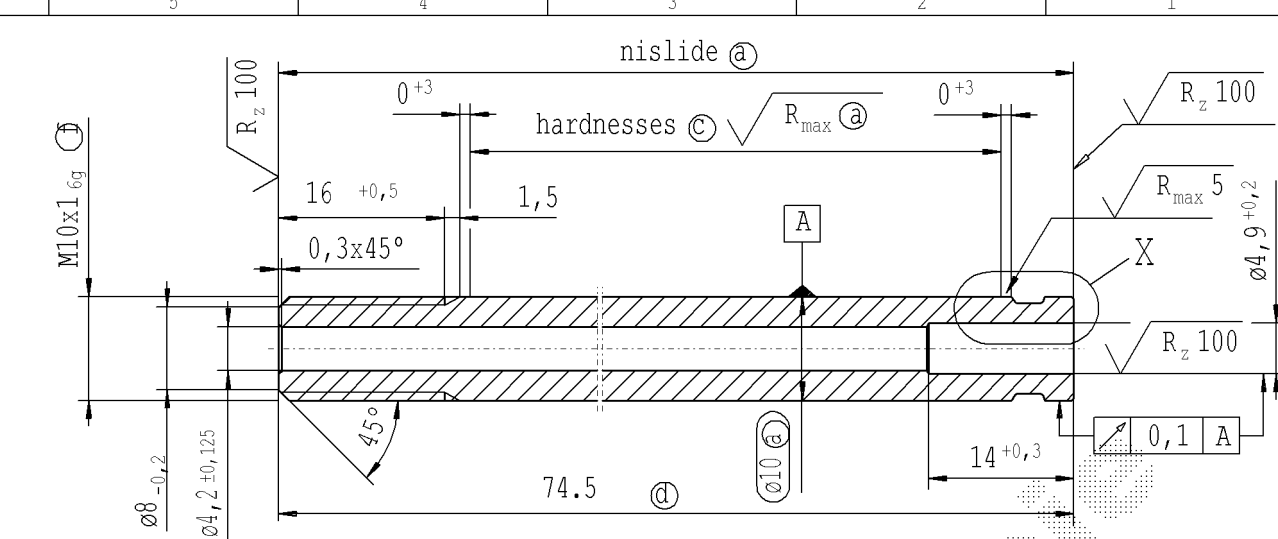

\* SUPPLIER DRAWING AVAILABLE

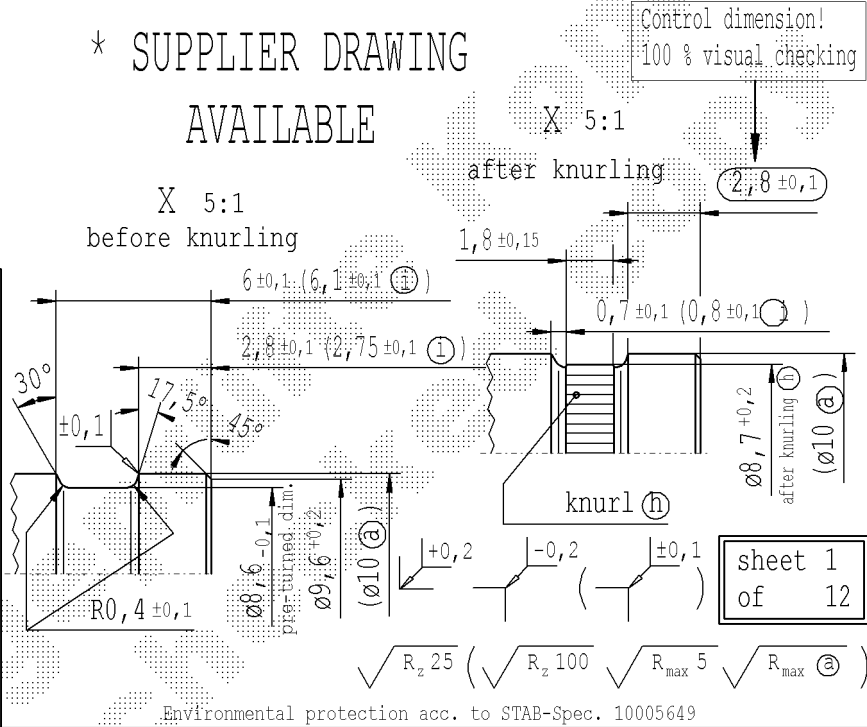

Material:	mat. no.: 010154	All dimensions are in mm	Marking of special characteristics according to STAB-Spec. 10270932	Drawn by	Date	Name
Edge tolerances acc. to DIN ISO 13715		Scale:	Dimensions without tolerances DIN ISO 2768-mK	Checked	10.06.1999	Pulze
Surface finish acc. to DIN EN ISO 1302		(Original DIN A3) 2:1			09.06.2021	Klinkner
Regulations:	Zehing: Nr. vom 24.01.94	We reserve all rights to this document, to any patents or patent registrations related hereto, and to the duplication, retransmission by third parties and misc. use. Any use of this document is not permitted without the written consent of STABILUS.		Document No.:		
<b>STABILUS</b>				10004301		
PISTON ROD				Material No.:		