

The print-out is not subject to the modification service.

Intended for internal and supplier use

Ident. Doc.: 30/2/2023 - 13:19

supp No.	material no.	overall length
	Surface treatment STAB-Spec. 10028959 Tab.I (b)	A
1	682626	162.0
2	100186	147.0
3	105922	144.0
4	112375	201.0
5	113331	249.0
6	913981	381.0
7	561935	168.0
8	563608	261.0
9	575558	363.0
10	308357	84.0
11	473034	265.5
12	356405	204.0
13	387475	258.0
14	129834	210.0
xx	xxxxxxx	234

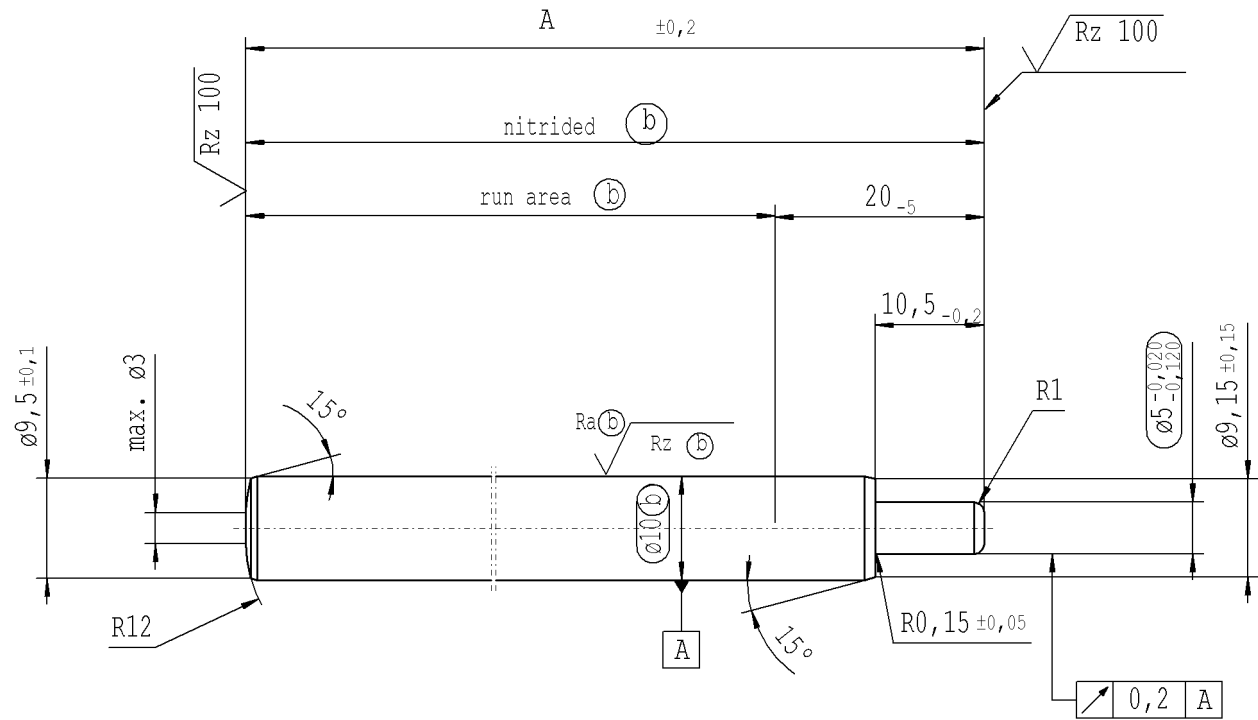

external production * material: 1.1193 S45C JISG 4051

approved lengths: 50-600 mm

$\sqrt{Rz\ 25}$ ($\sqrt{Rz\ 100}$ $Ra\ (b)$ $Rz\ (b)$) $\sqrt{\pm 0,2}$ $\sqrt{-0,2}$

sheet 1
of 1

AIAG CQI-standards acc. to STAB-Spec. 10027692										Environmental protection acc. to STAB-Spec. 10005649									
DE: X	EN: X	ES:	IT:	PR:	FR:	RO: X	CAD created document; handwritten changes not permitted			Material:	*	All dimensions are in mm	Marking of special characteristics according to STAB-Spec. 10270932			Drawn by	10.12.2019	Höfer	
new	INITIAL RELEASE		new format Supplier									Scale: (Original DIN A3) 2:1			Checked	09.11.2020	Klinkner		
old	-		Supplier drawing separately							Edge tolerances acc. to DIN ISO 13715		Dimensions without tolerances DIN ISO 2768-mK			Document No.: 10272399				
Field	-		-							Surface finish	DIN EN ISO 1302	We reserve all rights to this document, to any patents or patent registrations related hereto, and to the duplication, retransmission by third parties and misc. use. Any use of this document is not permitted without the written consent of STABILUS.			Material No.:				
Date/Name	10.12.2019 Höfer		09.11.2020 Donat							Replaces:									
Chg. No.	-		692776																
Rev.	0		1							STABILUS		PISTON ROD							

