

The print-out is not subject to the modification service.

CONFIDENTIAL! Intended for internal and supplier use

EN

B

Ident. Doc.:

supp No.	material no.			A	E
	processing and surface treatment acc. to STAB-Spec. 10006248 Tab. XVI optimized version 1	10006248 Tab. X version 1	10028959 Tab. I version 2	overall length	length without unfitting stud
1	008598	008598	008598	395.5	387.0
2	008599	008599	008599	135.0	126.5
3	005510	005510	005510	243.5	235.0
4	005519	005519	005519	251.0	242.5
5	005520	005520	005520	174.0	165.5
6	005535	005535	005535	144.0	135.5
7	005543	005543	005543	262.0	253.5
9	005561	005561	005561	201.0	192.5
10	005577	005577	005577	249.0	240.5
11	005596	005596	005596	165.5	157.0
12	005599	005599	005599	276.0	267.5
13	005603	005603	005603	354.0	345.5
14	005611	005611	005611	153.0	144.5
15	005616	005616	005616	216.0	207.5
16	005630	005630	005630	134.5	126.0
17	005680	005680	005680	198.0	189.5
18	005686	005686	005686	213.0	204.5
19	005693	005693	005693	379.5	371.0
20	005697	005697	005697	150.0	141.5

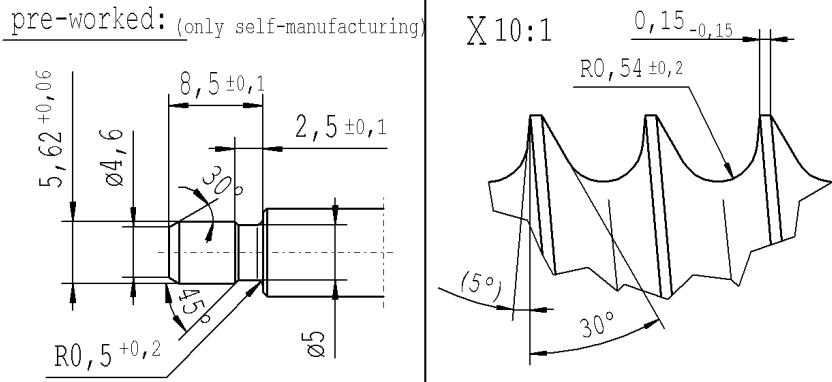
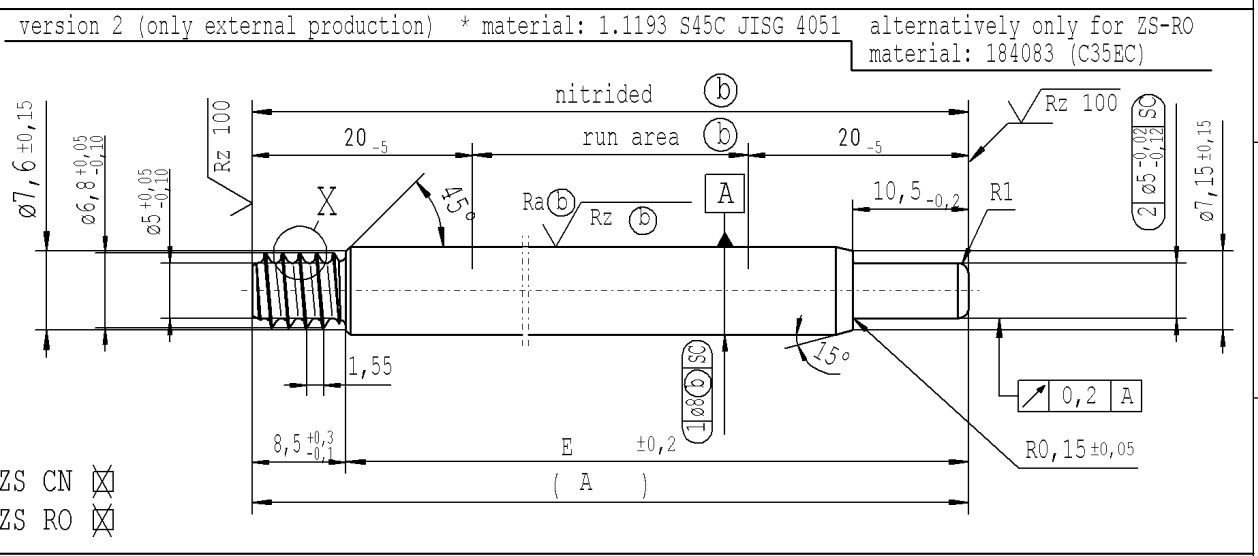
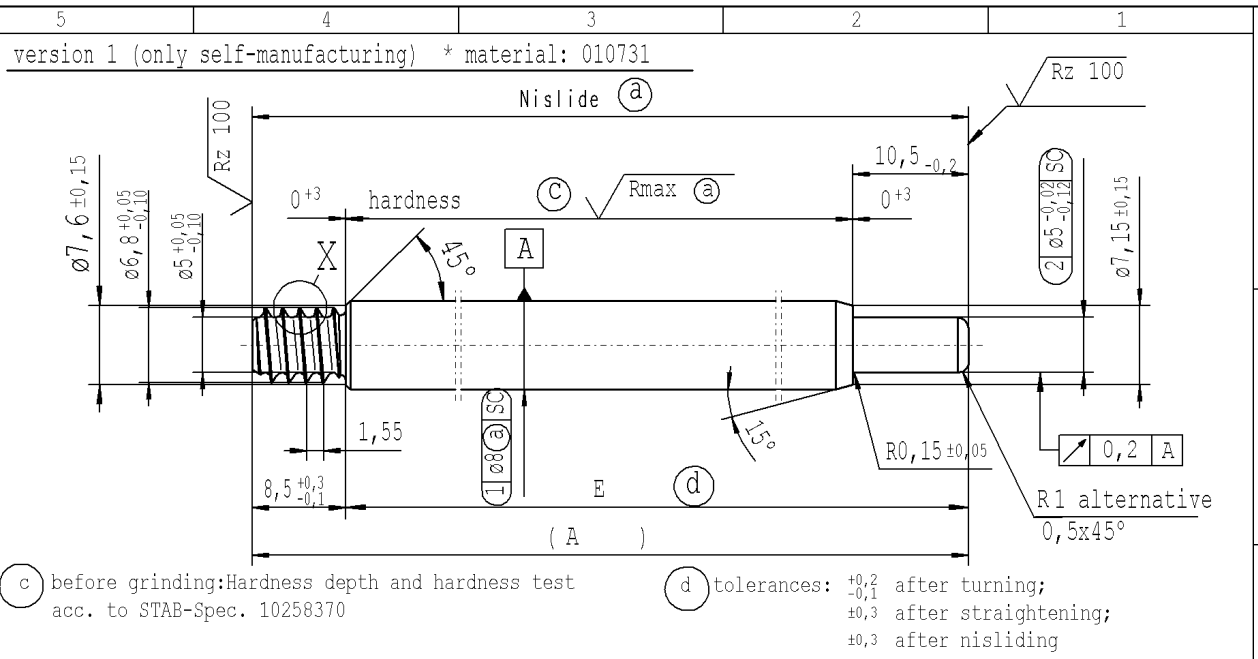

AIAG CQI-standards acc. to STAB-Spec. 10027692				Environmental protection acc. to STAB-Spec. 10005649								
DE: X	EN: X	ES: X	IT:	PR: X	FR:	RO: X	CAD created document; handwritten changes not permitted	Material: *	All dimensions are in mm	Marking of special characteristics according to STAB-Spec. 10270932	Date	Name
new	Text "approved lengths: ... mm" deleted; no technical change, no new first sample required			ø7,6 ±0,15 x45°					Scale: (Original DIN A3) 2:1	Dimensions without tolerances DIN ISO 2768-mK	Drawn by	Höfer
old								Edge tolerances acc. to DIN ISO 13715			Checked	Klinkner
Field								Surface finish DIN EN ISO 1302			Document No.: 10151065	
Date/Name	22.07.2024 Jablonski			18.09.2024 Donat				Replaces:	We reserve all rights to this document, to any patents or patent registrations related hereto, and to the duplication, retransmission by third parties and misc. use. Any use of this document is not permitted without the written consent of STABILUS.			
Chg. No.	733040			735210				STABILUS	PISTON ROD			
Rev.	22			23								