

CAD-SYSTEM UNIGRAPHICS ID:10000074666-UGD_000_04

The print-out is not subject to the modification service

CONFIDENTIAL!
Intended for internal use only

EN

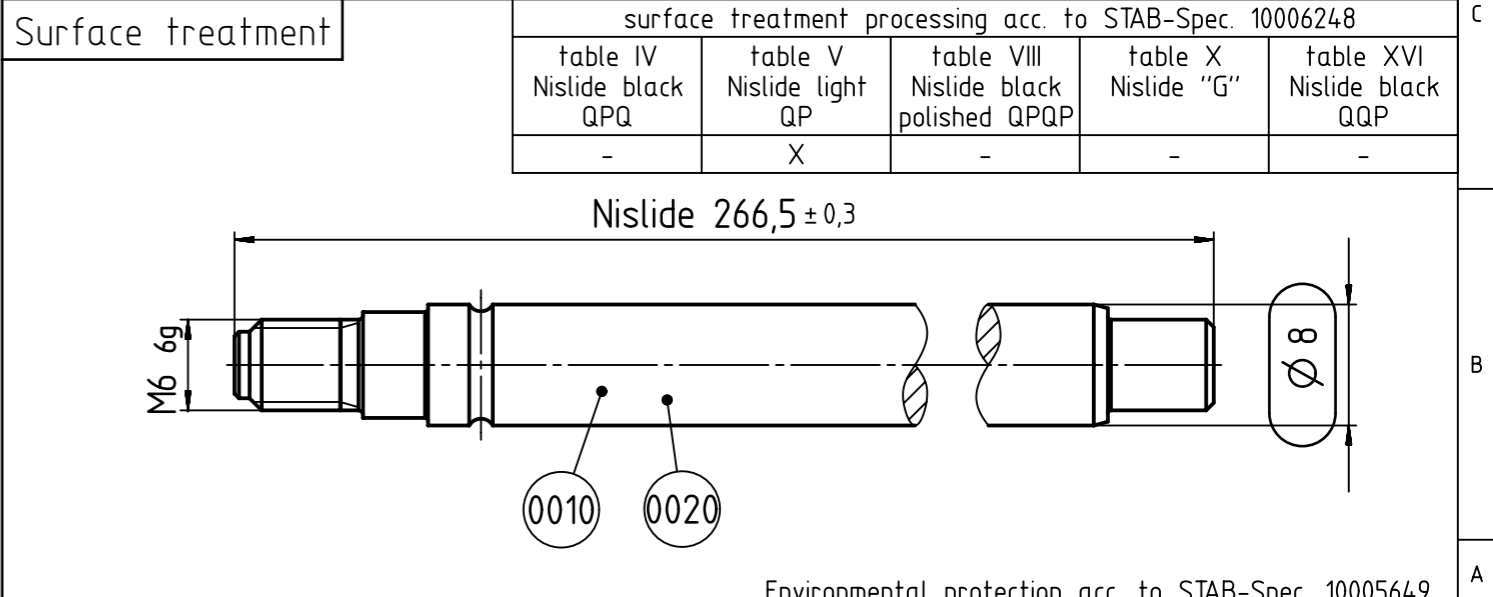
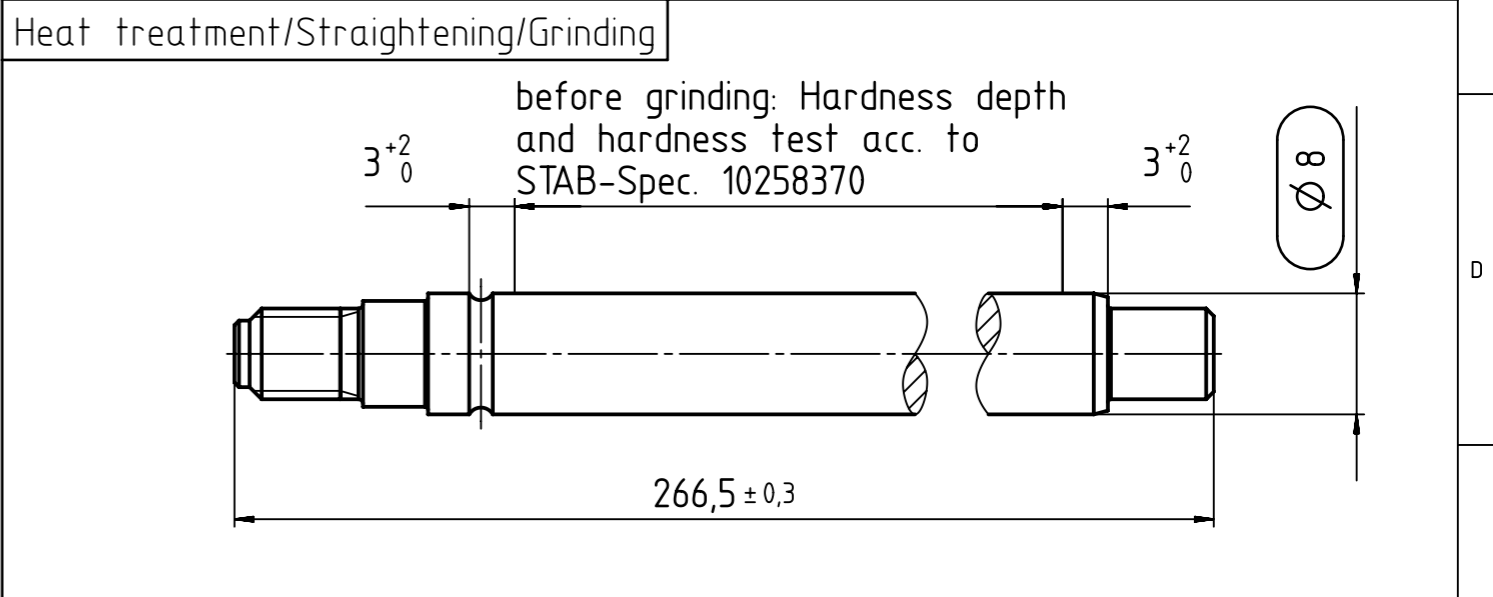
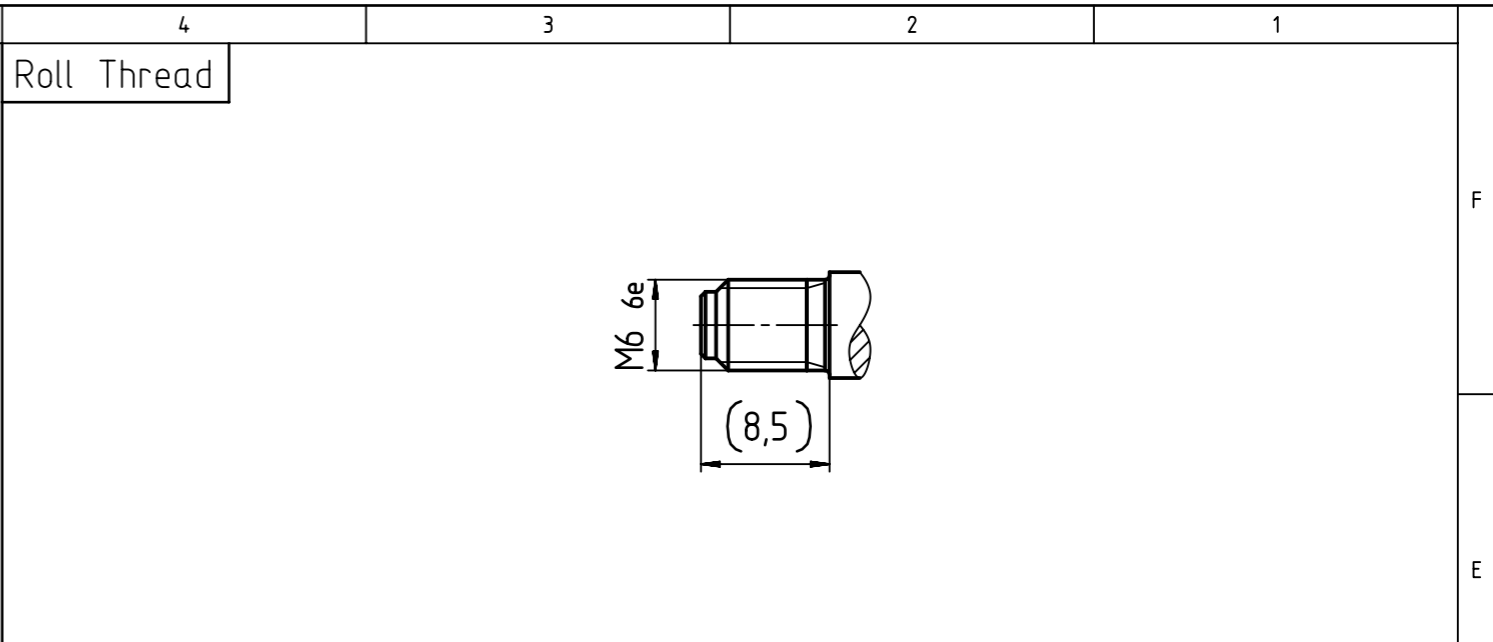
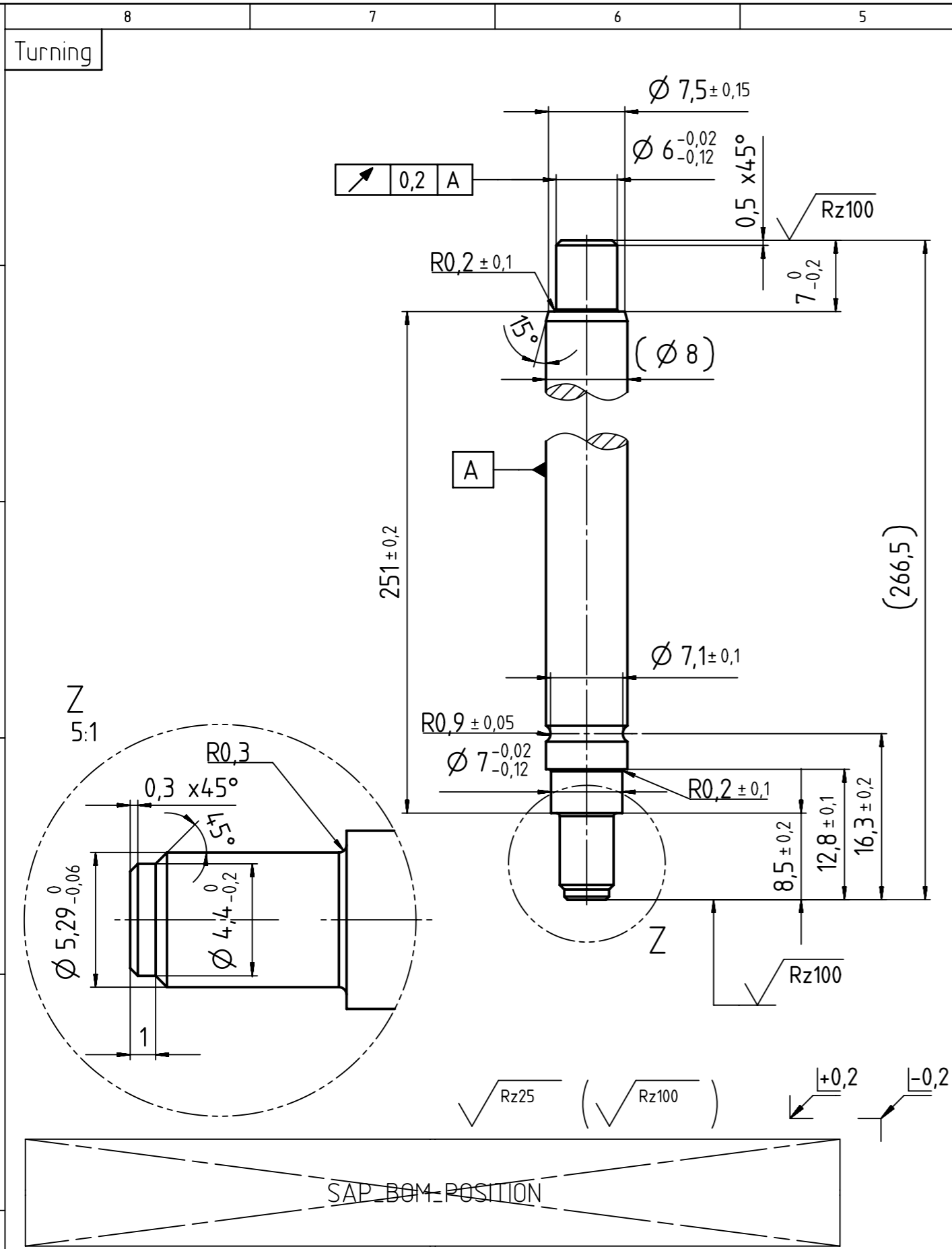

DE: X	EN: X	ES:	IT:	PT:	FR:	RO:
new	Hardness depth and hardness...					
old	hardness > 68 HRA...					
Field	D2					
Date/Name	12.04.2019 Jablonski					
Change No	677808					
Revision	4					

Material: S45C	All dimensions are in mm	Identification of important characteristics	Date	Name
Edge tolerances acc. to DIN ISO 13715	Scale: (Original DIN A3) 2:1	Dimensions without tolerances DIN ISO 2768-mK	Drawn by	15.03.2013 Hein.C.
Surface finish DIN EN ISO 1302	We reserve all rights to this document, to any patents or patent registrations related hereto, and to the duplication, retransmission by third parties and misc. use. Any use of this document is not permitted without the written consent of STABILUS. CAD created document; handwritten changes not permitted		Checked	15.04.2019 Klinkner.B.
Replaces: change no. 655939	Document No.: 10202045		Material No.: 468693	
STABILUS	PISTON ROD			